

TECHNICAL DATA

U_{max}	1.96 V	$T_{hot}=25^{\circ}C$ Vacuum
Q_{max}	5.0 W	
ΔT_{max}	72°	
I_{max}	4.3 A	
ACR at 25°C	0.4 Ohm	
Pad type	Hot side Cold side	Ceramics Al_2O_3 , white 96%
Max. processing temperature	Depends on chosen solder type	
Standard tolerances for thermal and electrical parameters $\pm 10\%$		

MODULE DRAWING
standard design

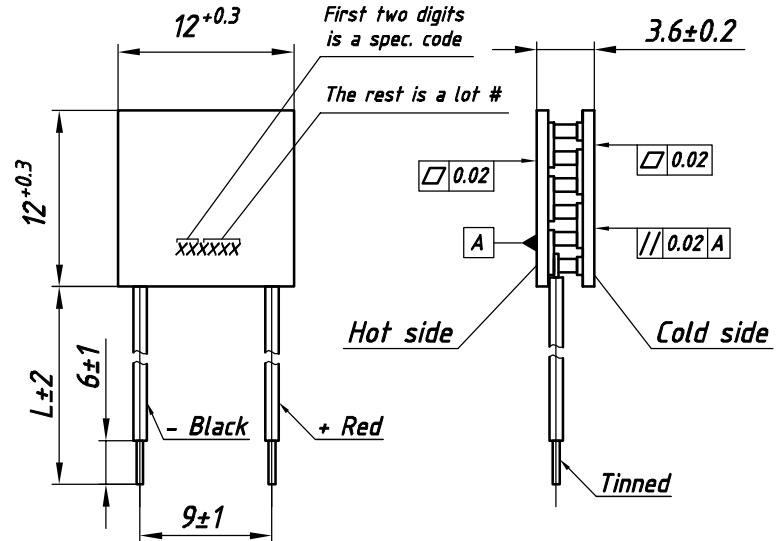

STANDARD ORDERING OPTIONS

Nº	Option	Parameter
1	Lead wires	AWG Nº
		20 22 24
		L - under customer request
2	Lead wires length	Type / Max. processing temp.
		Without insulation / See solder type m.p.t
		PVC-1 / 85° C
		PVC-2 / 105° C
		Silicone / 180° C
3	Lead wires insulation	PTFE / 200° C
		Type / Max. processing temp.
		Type-1 / 138° C
		Type-2 / 183° C *
4	Internal solder	Type-3 / 227° C
		Type-4 / 232° C
		Anticorrosional coating
5	Sealing	Type / Max. processing temp.
		Without sealing / 200° C
		Epoxy / 130° C
		Silicone / 180° C

AVAILABLE MODIFICATIONS

Design	Description
TM-17-1.0-3.9 M	High reliable version on cold side

OPTIONS UPON REQUEST

Height tolerance	± 0.02
Unflatness and nonparallelism	± 0.02
Porch-style design	

- Solder type marked * is not compliant to RoHS (2002/95/EC)
- For another options consult of our technical support engineers

Performance graphs for TM-17-1.0-3.9 module at $T_h=25\text{ }^\circ\text{C}$
 Environment: vacuum

