

**TECHNICAL DATA**

$U_{max}$	2.1 V	$T_{hot}=25^{\circ}C$ Vacuum
$Q_{max}$	98 W	
$\Delta T_{max}$	72°	
$I_{max}$	80.0 A	
ACR at 25°C	0.023 Ohm	
Pad type	Hot side	Ceramics $Al_2O_3$ , white 96%
	Cold side	
Max. processing temperature	Depends on chosen solder type	
Standard tolerances for thermal and electrical parameters $\pm 10\%$		

**MODULE DRAWING**  
standard design

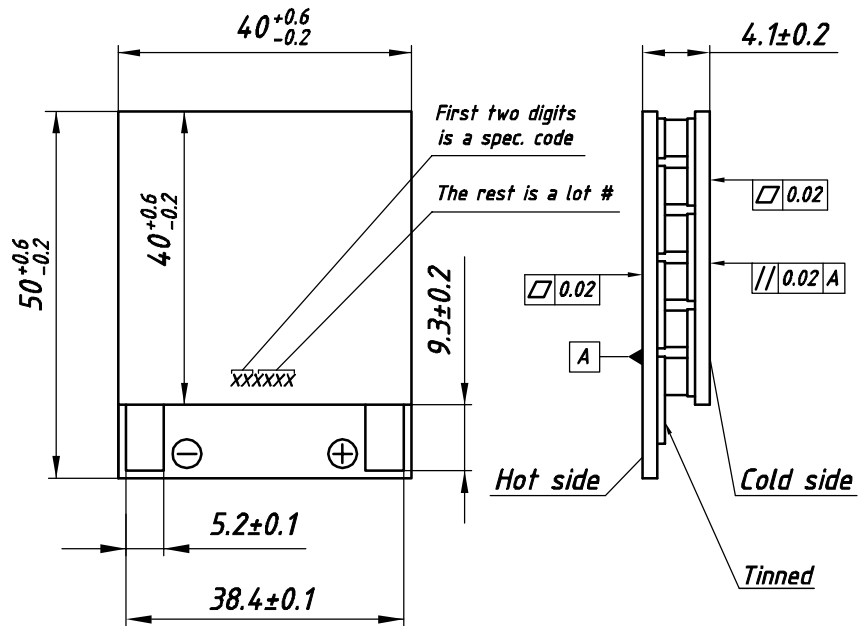

**STANDARD ORDERING OPTIONS**

Nº	Option	Parameter
1	Lead wires	Under customer request
2	Lead wires length	L - under customer request
3	Lead wires insulation	Type / Max. processing temp.
		Without insulation / See solder type m.p.t
		PVC-1 / 85° C
		PVC-2 / 105° C
		Silicone / 180° C
4	Internal solder	Type / Max. processing temp.
		Type-1 / 138° C
		Type-2 / 183° C *
		Type-3 / 227° C
5	Anticorrosional coating	yes      no
6	Sealing	Type / Max. processing temp.
		Without sealing / 200° C
		Epoxy / 130° C
		Silicone / 180° C

**AVAILABLE MODIFICATIONS**

Design	Description
TM-18-5.0-60.0 M	Porch-style design with high reliable version on cold side

**OPTIONS UPON REQUEST**

Height tolerance	$\pm 0.02$
Unflatness and nonparallelism	$\pm 0.02$

- Solder type marked \* is not compliant to RoHS (2002/95/EC)
- For another options consult of our technical support engineers

Performance graphs for TM-18-5.0-75.0 module at Th=25 °C  
Environment: vacuum

