

**TECHNICAL DATA**

$U_{max}$	23.4 V	$T_{hot}=25^{\circ}C$ Vacuum
$Q_{max}$	160 W	
$\Delta T_{max}$	72°	
$I_{max}$	12.0 A	
ACR at 25°C	1.75 Ohm	
Pad type	Hot side Cold side	Ceramics $Al_2O_3$ , white 96%
Max. processing temperature	Depends on chosen solder type	
Standard tolerances for thermal and electrical parameters $\pm 10\%$		

**MODULE DRAWING**  
*standard design*

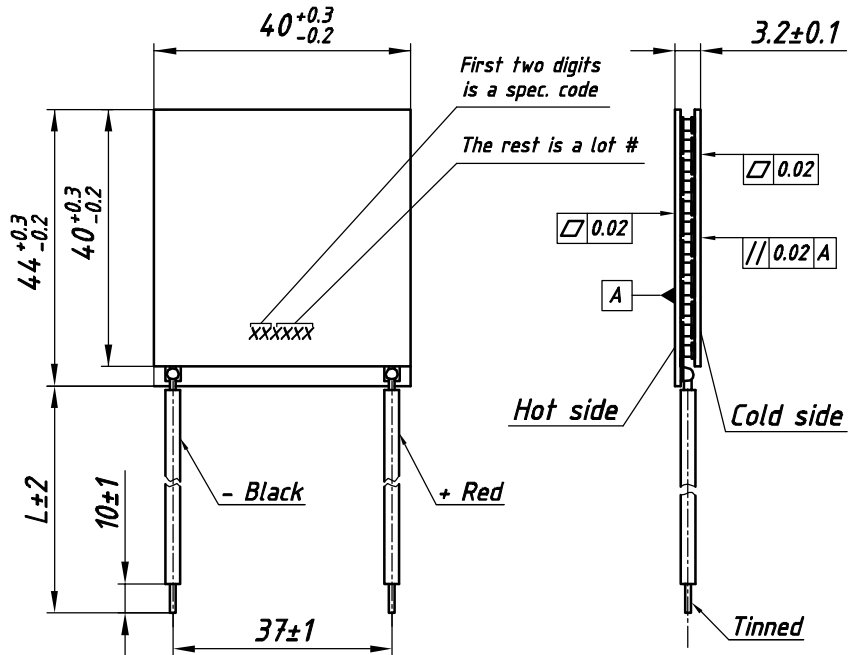

**STANDARD ORDERING OPTIONS**

Nº	Option	Parameter	
1	Lead wires	AWG Nº	
		18	20
2	Lead wires length	L - under customer request	
3	Lead wires insulation	Type / Max. processing temp.	
		Without insulation / See solder type m.p.t	
		PVC-1 / 85° C	
		PVC-2 / 105° C	
		Silicone / 180° C	
4	Internal solder	Type / Max. processing temp.	
		Type-1 / 138° C	
		Type-2 / 183° C *	
		Type-3 / 227° C	
5	Anticorrosional coating	yes	no
		Type / Max. processing temp.	
6	Sealing	Without sealing / 200° C	
		Epoxy / 130° C	
		Silicone / 180° C	

**AVAILABLE MODIFICATIONS**

Design	Description
TMC-199-1.4-12.0 M	Porch-style design with high reliable version on cold side for thermal cycling applications

**OPTIONS UPON REQUEST**

Height tolerance	$\pm 0.02$
Unflatness and nonparallelism	$\pm 0.02$

- Solder type marked \* is not compliant to RoHS (2002/95/EC)
- For another options consult of our technical support engineers

Performance graphs for TM-199-1.4-12.0 module at  $T_h=25\text{ }^\circ\text{C}$   
 Environment: vacuum

