

TECHNICAL DATA

U_{max}	28.3 V	$T_{hot}=25^{\circ}C$ Vacuum
Q_{max}	240 W	
ΔT_{max}	72°	
I_{max}	15.0 A	
ACR at 25°C	1.7 Ohm	
Pad type	Hot side Cold side	Ceramics Al_2O_3 , white 96%
Max. processing temperature	Depends on chosen solder type	
Standard tolerances for thermal and electrical parameters $\pm 10\%$		

MODULE DRAWING
standard design

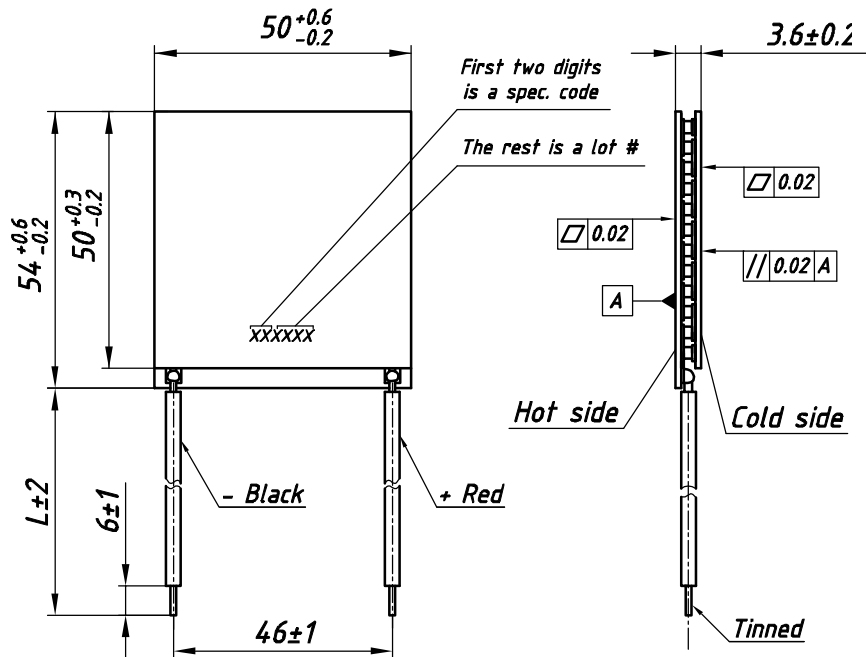

STANDARD ORDERING OPTIONS

Nº	Option	Parameter	
1	Lead wires	AWG Nº	
		18	20
2	Lead wires length	L - under customer request	
3	Lead wires insulation	Type / Max. processing temp.	
		Without insulation / See solder type m.p.t	
		PVC-1 / 85° C	
		PVC-2 / 105° C	
		Silicone / 180° C	
4	Internal solder	Type / Max. processing temp.	
		Type-1 / 138° C	
		Type-2 / 183° C *	
		Type-3 / 227° C	
5	Anticorrosional coating	yes	no
		Type / Max. processing temp.	
6	Sealing	Without sealing / 200° C	
		Epoxy / 130° C	
		Silicone / 180° C	

AVAILABLE MODIFICATIONS

Design	Description
TM-241-1.6-15.0 M	Porch-style design with high reliable version on cold side
TMC-241-1.6-15.0 MM	Porch-style design with high reliable version on both sides for thermal cycling applications

OPTIONS UPON REQUEST

Height tolerance	± 0.02
Unflatness and nonparallelism	± 0.02

- Solder type marked * is not compliant to RoHS (2002/95/EC)
- For another options consult of our technical support engineers

Ferrotec Nord Corp.
 www.ferrotec-nord.com
 e-mail: info@ferrotec-nord.com
 phone: +7 (499) 357-67-71
 Peschany Carrier 3, 109383 Moscow, Russia

Performance graphs for TM-241-1.6-15.0 module at $T_h=25\text{ }^\circ\text{C}$
 Environment: vacuum

