

TECHNICAL DATA

U_{max}	53.4 V	$T_{hot}=25^{\circ}C$ Vacuum
Q_{max}	103.8 W	
ΔT_{max}	72°	
I_{max}	3.5 A	
ACR at 25°C	13.7 Ohm	
Pad type	Hot side	Ceramics Al ₂ O ₃ , white 96%
	Cold side	
Max. processing temperature	Depends on chosen solder type	
Standard tolerances for thermal and electrical parameters ±10%		

MODULE DRAWING
standard design

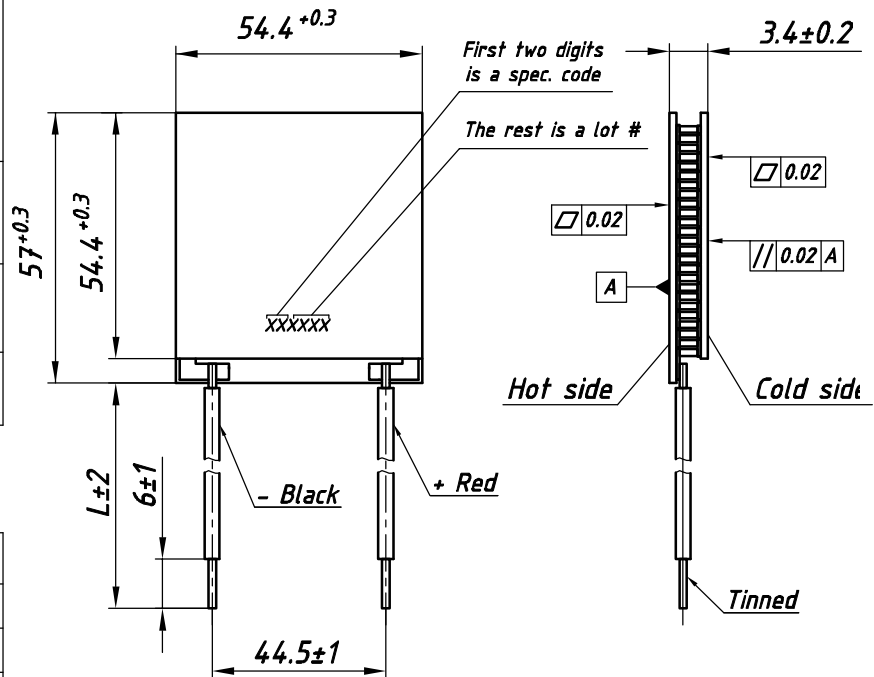

STANDARD ORDERING OPTIONS

Nº	Option	Parameter
1	Lead wires	AWG Nº
		20 22 24
		L - under customer request
3	Lead wires insulation	Type / Max. processing temp.
		Without insulation / See solder type m.p.t
		PVC-1 / 85° C
		PVC-2 / 105° C
		Silicone / 180° C
4	Internal solder	Type / Max. processing temp.
		Type-1 / 138° C
		Type-2 / 183° C *
		Type-3 / 227° C
5	Anticorrosional coating	yes no
		Type / Max. processing temp.
6	Sealing	Without sealing / 200° C
		Epoxy / 130° C
		Silicone / 180° C

AVAILABLE MODIFICATIONS

Design	Description
TM-450-0.8-3.0 MM	Porch-style design with high reliable version on both sides

OPTIONS UPON REQUEST

Height tolerance	± 0.02
Unflatness and nonparallelism	± 0.02

- Solder type marked * is not compliant to RoHS (2002/95/EC)
- For another options consult of our technical support engineers

Performance graphs for TM-450-0.8-3.0 module at Th=25 °C
Environment: vacuum

