

TM-71-1.4-9.0

TECHNICAL DATA

U_{max}	8.2 V	$T_{hot}=25^{\circ}C$ Vacuum
Q_{max}	42 W	
ΔT_{max}	72°	
I_{max}	9.0 A	
ACR at 25°C	0.84 Ohm	
Pad type	Hot side	Ceramics Al_2O_3 , white 96%
	Cold side	
Max. processing temperature	Depends on chosen solder type	
Standard tolerances for thermal and electrical parameters $\pm 10\%$		

MODULE DRAWING standard design

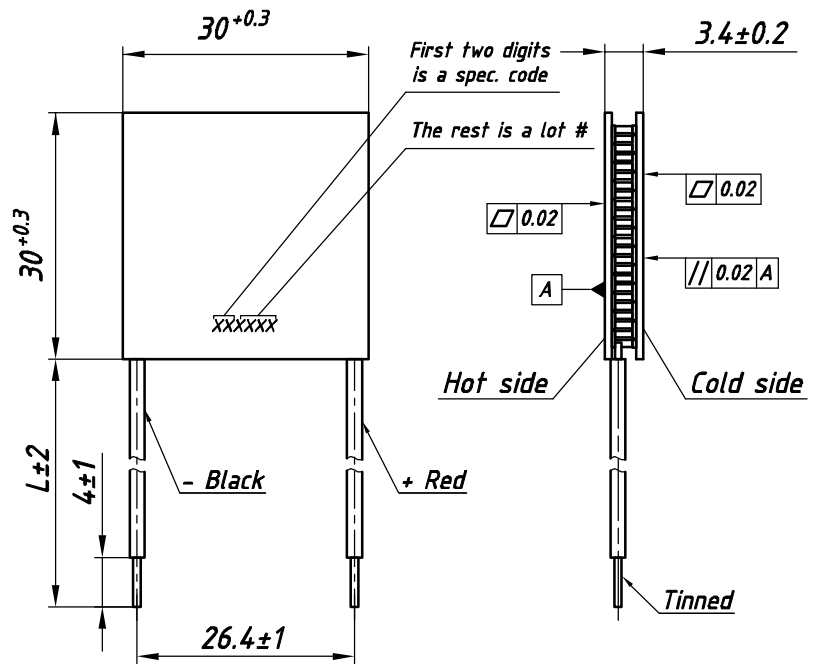

STANDARD ORDERING OPTIONS

Nº	Option	Parameter	
1	Lead wires	AWG Nº	
		18	20
2	Lead wires length	L - under customer request	
3	Lead wires insulation	Type / Max. processing temp.	
		Without insulation / See solder type m.p.t	
		PVC-1 / 85° C	
		PVC-2 / 105° C	
		Silicone / 180° C	
4	Internal solder	Type / Max. processing temp.	
		Type-1 / 138° C	
		Type-2 / 183° C *	
		Type-3 / 227° C	
5	Anticorrosional coating	yes	no
		Type / Max. processing temp.	
6	Sealing	Without sealing / 200° C	
		Epoxy / 130° C	
		Silicone / 180° C	
		Type / Max. processing temp.	

AVAILABLE MODIFICATIONS

Design	Description
TM-71-1.4-9.0 M	High reliable version on cold side
TMC-71-1.4-9.0 MM	High reliable version on both sides for thermal cycling applications

OPTIONS UPON REQUEST

Height tolerance	± 0.02
Unflatness and nonparallelism	± 0.02
Porch-style design	

- Solder type marked * is not compliant to RoHS (2002/95/EC)
- For another options consult of our technical support engineers

Performance graphs for TM-71-1.4-9.0 module at Th=25 °C
Environment: vacuum

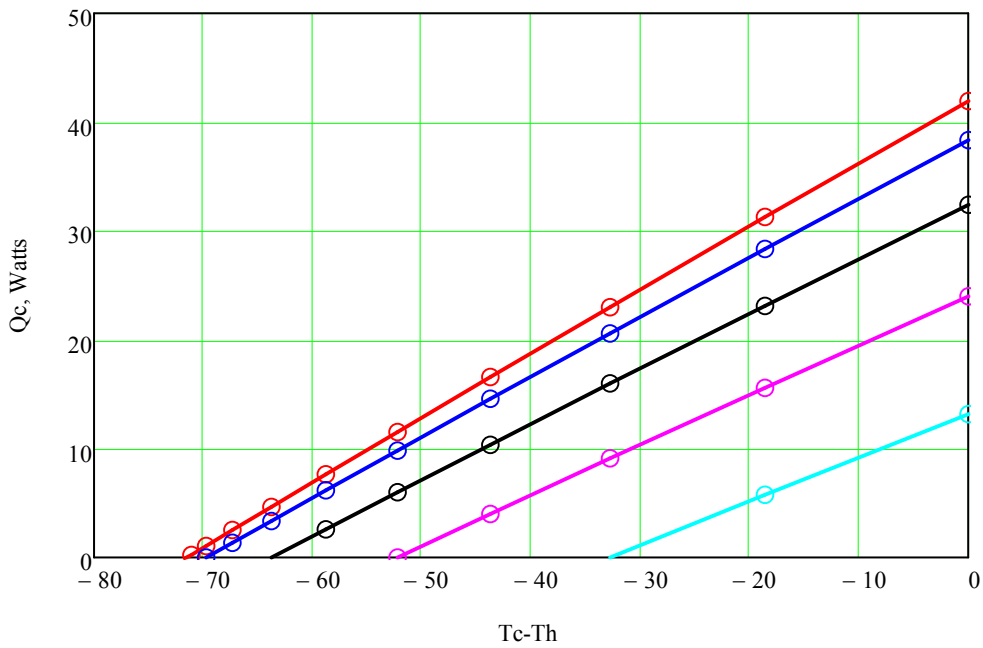

- I=Imax
- I=0.8Imax
- I=0.6Imax
- I=0.4Imax
- I=0.2Imax

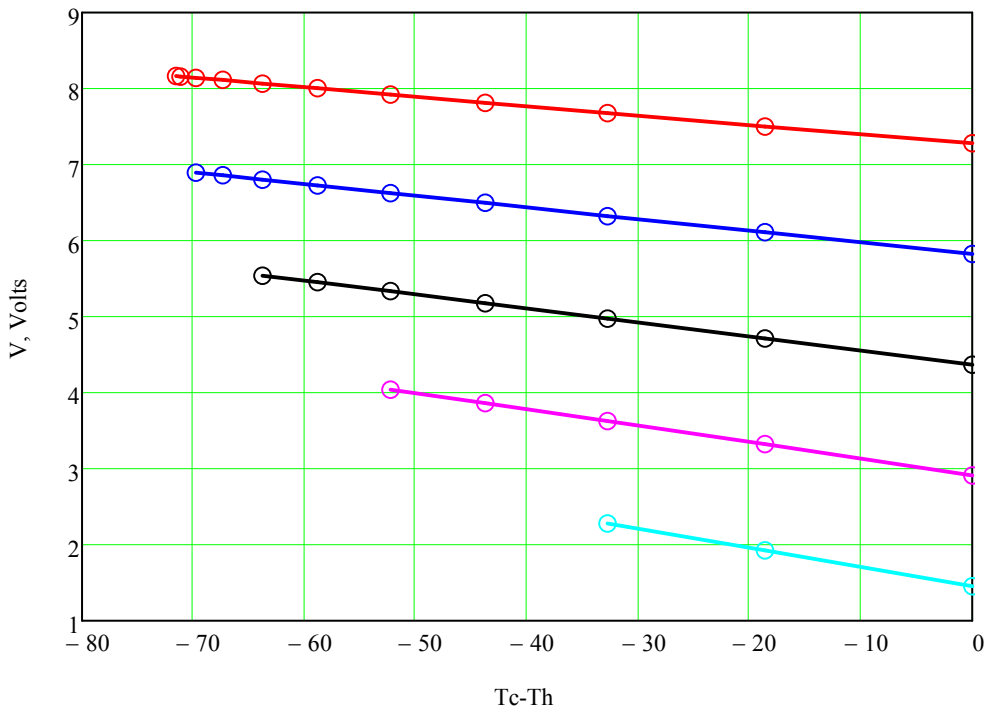

- I=Imax
- I=0.8Imax
- I=0.6Imax
- I=0.4Imax
- I=0.2Imax