

TECHNICAL DATA

U_{max}	4.0 V	$T_{hot}=25^{\circ}C$ Vacuum
Q_{max}	20.7 W	
ΔT_{max}	72°	
I_{max}	8.7 A	
ACR at 25°C	0.41 Ohm	
Pad type	Hot side	Ceramics Al_2O_3 , white 96%
	Cold side	
Max. processing temperature	Depends on chosen solder type	
Standard tolerances for thermal and electrical parameters $\pm 10\%$		

MODULE DRAWING
standard design

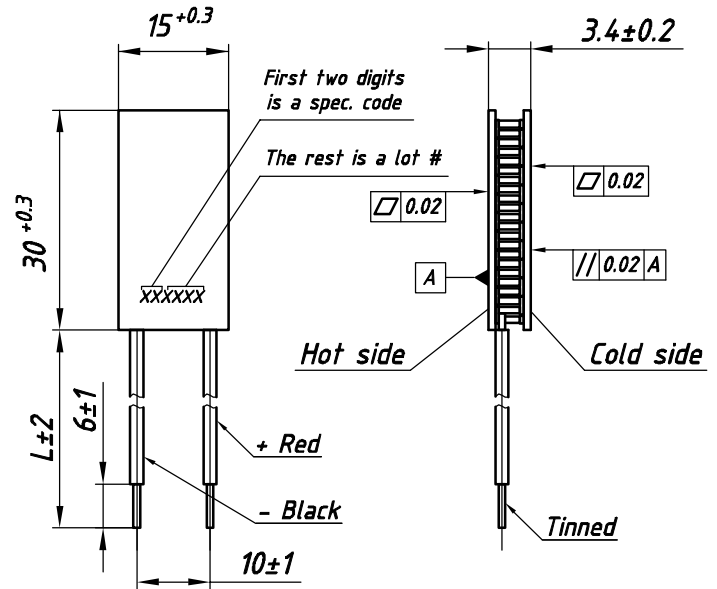

STANDARD ORDERING OPTIONS

Nº	Option	Parameter		
1	Lead wires	AWG Nº		
		18	20	22
		L - under customer request		
3	Lead wires insulation	Type / Max. processing temp.		
		Without insulation / See solder type m.p.t		
		PVC-1 / 85° C		
		PVC-2 / 105° C		
		Silicone / 180° C		
		PTFE / 200° C		
4	Internal solder	Type / Max. processing temp.		
		Type-1 / 138° C		
		Type-2 / 183° C *		
		Type-3 / 227° C		
		Type-4 / 232° C		
5	Anticorrosional coating	yes	no	
		Type / Max. processing temp.		
6	Sealing	Without sealing / 200° C		
		Epoxy / 130° C		
		Silicone / 180° C		

AVAILABLE MODIFICATIONS

Design	Description
TM-35-1.4-8.5 M	High reliable version on cold side

OPTIONS UPON REQUEST

Height tolerance	± 0.02
Unflatness and nonparallelism	± 0.02
Porch-style design	

- Solder type marked * is not compliant to RoHS (2002/95/EC)
- For another options consult of our technical support engineers

Performance graphs for TM-35-1.4-8.5 module at $T_h=25\text{ }^\circ\text{C}$
 Environment: vacuum

